

DIGITAL BOOSTER AMPLIFIER

P-3248D-EB 1CE

P-3248D-EB 4CE

Please follow the instructions in this manual to obtain the optimum results from this unit.
We also recommend that you keep this manual handy for future reference.

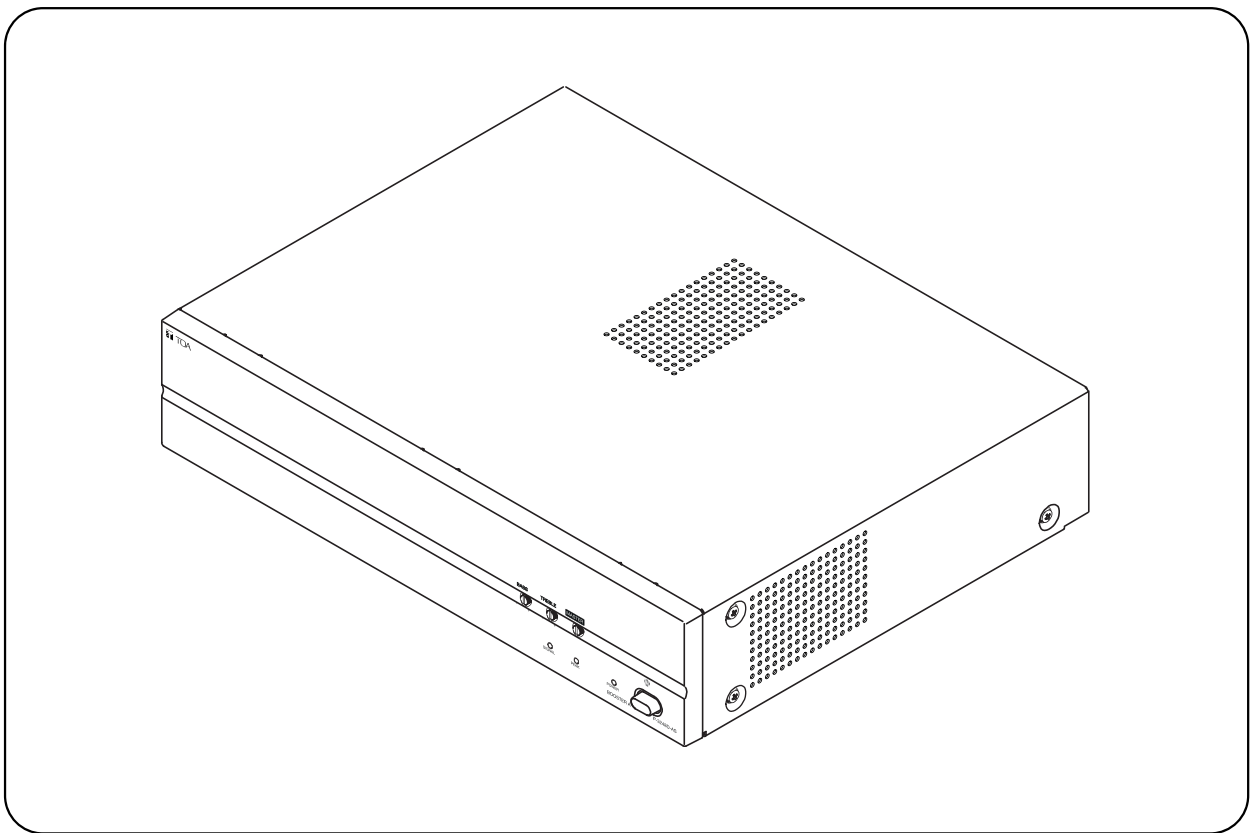

TABLE OF CONTENTS

1. SAFETY PRECAUTIONS	2	5.2. Speaker Connections	6
2. GENERAL DESCRIPTION	3	5.3. Example of External Equipment	
3. FEATURES	3	Connections	6
4. NOMENCLATURES AND FUNCTIONS		6. INSTALLATION	7
4.1. Front Panel	3	7. BLOCK AND LEVEL DIAGRAM	7
4.2. Rear Panel	3	8. DIMENSIONAL DIAGRAM	7
5. CONNECTIONS		9. SPECIFICATIONS	8
5.1. Input Connections	5		

1. SAFETY PRECAUTIONS

- Before installation or use, be sure to carefully read all the instructions in this section for correct and safe operation.
- Be sure to follow all the precautionary instructions in this section, which contain important warnings and/or cautions regarding safety.
- After reading, keep this manual handy for future reference.

Safety Symbol and Message Conventions

Safety symbols and messages described below are used in this manual to prevent bodily injury and property damage which could result from mishandling. Before operating your product, read this manual first and understand the safety symbols and messages so you are thoroughly aware of the potential safety hazards.



WARNING

Indicates a potentially hazardous situation which, if mishandled, could result in death or serious personal injury.

When Installing The Unit

- Do not expose the unit to rain or an environment where it may be splashed by water or other liquids, as doing so may result in fire or electric shock.
- Use the unit only with the voltage specified on the unit. Using a voltage higher than that which is specified may result in fire or electric shock.
- Do not cut, kink, otherwise damage nor modify the power supply cord. In addition, avoid using the power cord in close proximity to heaters, and never place heavy objects including the unit itself on the power cord, as doing so may result in fire or electric shock.
- The terminals marked with the symbol  are hazardous live. The external wiring to these terminals requires installation by an instructed person.
- Be sure to replace the unit's terminal cover after connection completion. Because the voltage of up to 100V is applied to the high impedance speaker terminals, never touch terminals to avoid electric shock.
- Be sure to ground to the safety ground (earth) terminal to avoid electric shock. Never ground to a gas pipe as a catastrophic disaster may result.

When The Unit is in Use

- Should the following irregularity be found during use, immediately switch off the power, disconnect the power supply plug from the AC outlet and contact your nearest TOA dealer. Make no further attempt to operate the unit in this condition as this may cause fire or electric shock.
 - If you detect smoke or a strange smell coming from the unit.
 - If water or any metallic object gets into the unit.
 - If the unit falls, or the unit case breaks.
 - If the power supply cord is damaged (exposure of the core, disconnection, etc.)
 - If it is malfunctioning (no tone sounds.)
- To prevent a fire or electric shock, never open nor remove the unit case as there are high voltage components inside the unit. Refer all servicing to your nearest TOA dealer.
- Do not place cups, bowls, or other containers of liquid or metallic objects on top of the unit. If they accidentally spill into the unit, this may cause a fire or electric shock.
- Do not insert nor drop metallic object or flammable materials in the ventilation slots of the unit's cover, as this may result in fire or electric shock.
- Class I construction shall be connected to a main socket outlet with a protective earthing connection.



CAUTION

Indicates a potentially hazardous situation which, if mishandled, could result in moderate or minor personal injury, and/or property damage.

When Installing The Unit

- Never plug in nor remove the power supply plug with wet hands, as doing so may cause electric shock.
- When unplugging the power supply cord, be sure to grasp the power supply plug, never pull on the cord itself. Operating the unit with a damaged power supply cord may cause a fire or electric shock.
- When moving the unit, be sure to remove its power supply cord from the wall outlet. Moving the unit with the power cord connected to the outlet may cause damage to the power cord, resulting in fire or electric shock. When removing the power cord, be sure to hold its plug to pull.

- Do not block the upper panel ventilation slots in the unit's cover. Doing so may cause heat to build up inside the unit and result in fire.
- Avoid installing the unit in humid or dusty location, in location exposed to direct sunlight, near the heaters, or in location generating sooty smoke or steam. As doing otherwise may result in fire or electric shock.

When The Unit is In Use

- Do not place heavy object on the unit as this may cause it to fall or break which may result in personal injury and/or property damage. In addition, the object itself may fall of and cause injury and/or damage.

2. GENERAL DESCRIPTION

TOA's Digital Booster Amplifier P-3248D-EB is high cost-performance booster amplifiers suited for broadcasting paging or background music in schools, offices, shops, factories, mosques, churches and large rooms.

3. FEATURES

- High durability, high reliability and high cost performance.
- Two balanced parallel inputs, one speaker line input.
- Speaker output of constant voltage distribution system (100 V) and low impedance (4 Ω).
- Operates on AC power.
- Semi fixed master volume control and independent speaker line input volume control.
- Semi fixed and independent tone controls of boost and cut type for both high and low frequencies.
- Remote power control by make contact input.

4. NOMENCLATURES AND FUNCTIONS

4.1. Front Panel

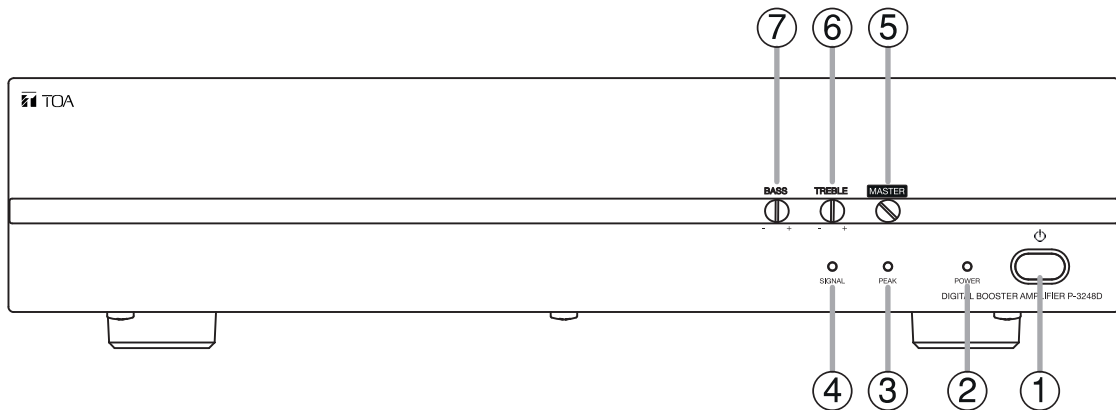

4.2. Rear Panel

P-3248D-EB 1CE

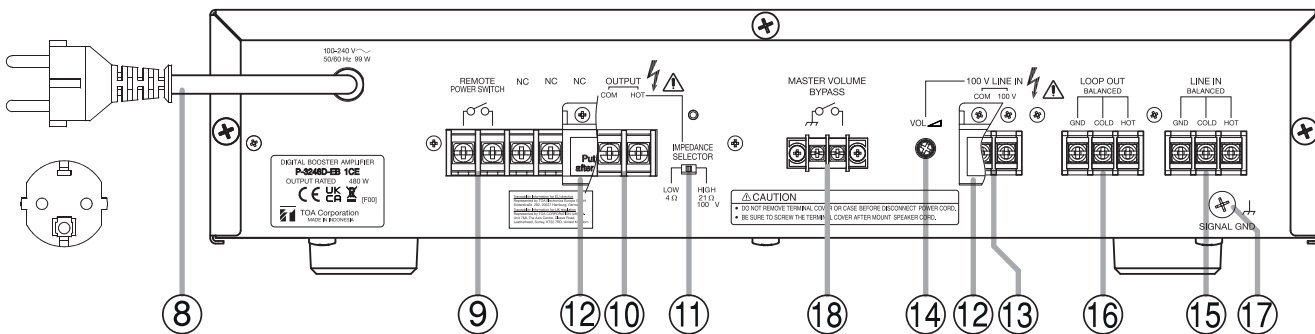

Note.
NC : not connected

P-3248D-EB 4CE

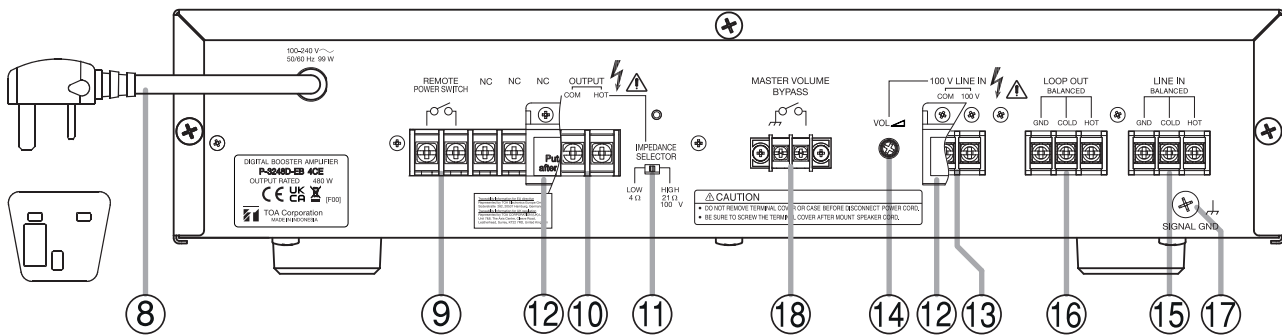

Note.
NC : not connected

1. **Power Switch**
Press to turn ON the power.
Press again to turn the power OFF.
2. **LED Power**
Lights green when power is switched ON.
3. **LED Peak**
Lights red to indicate the output signal is peak level, this indicates that sound is distortion. In such a case, adjust each volume control to reduce output level.
4. **LED Signal**
Lights green when power is switched ON, and indicates an output signal.
5. **Master Volume Control**
Adjusts the overall signal level.
6. **Treble Control**
Adjusts treble response. Rotate clockwise to increase treble output, and counterclockwise to reduce it. The center position provides flat characteristics.
7. **Bass Control**
Adjusts bass response. Rotate clockwise to increase bass output, and counterclockwise to reduce it. The center position provides flat characteristics.
8. **AC Power Cord**
Connects to an AC power source.
9. **Remote Power Control**
Connects to external switch. With unit's power switched ON, shorting Power Remote terminals can remotely turn off. With OFF, power cannot be remotely controlled.
10. **Output Terminals**
Connects to speakers. When connecting speakers use only one of the speaker output terminals, low or high impedance.
11. **Impedance Selector**
Selecting to 100 V for using high impedance type of loudspeaker connection or 4 Ω application.
Factory preset : 100 V
12. **Terminal Cover**
To cover high voltage from output/input terminal. Put back the terminal cover after connecting cords.
13. **100V Line Input**
40 dB, 30 kΩ, unbalanced. Connects to 100 V line speaker output.
14. **100V Line In Volume Control**
Adjusts the overall signal level.
15. **Line Input**
0 dB, 10 kΩ, balanced.
Connects to Line Out/Rec Out of Mixer Amplifier or Loop Out of other Power Amplifier.
16. **Loop Output**
0 dB, 10 kΩ, balanced.
Connects to Loop In of other Power Amplifier.
17. **Ground Terminal**
Connect to ground (earth) for safety and to avoid electric shock.
18. **Master Volume Bypass**
Connect to remote switch for emergency when master volume minimum position signal through.

EXPLANATION OF SYMBOLS

Front Panel



This symbol indicates a sleep mode or low power state. The switch does not fully disconnect the device from its power supply. Push the button to turn on the power or into standby mode.

Rear Panel



Do not touch the parts indicated with this symbol. These can provide a dangerous voltage that can result in death or serious personal injury when touching them.



Warning : This terminal/these terminals may provide a dangerous voltage. Do not touch, otherwise it may cause a serious personal injury or death!



This mark is a declaration that this product complies with all applicable EU directives and regulations.



This mark is a declaration that this product complies with all applicable UK directives and regulations.



Do not trash this device into normal waste. Use the foreseen electronic waste collection places.



This symbol stands for a functional earth terminal.

5. CONNECTIONS

5.1. Input Connections

- **Connection with the mixer pre amplifier having the balanced type output**

It recommends this connection when distance of the mixer pre amplifier is separated from this power amplifier more than 10 m or, in the location where there is a lot of electric noise.

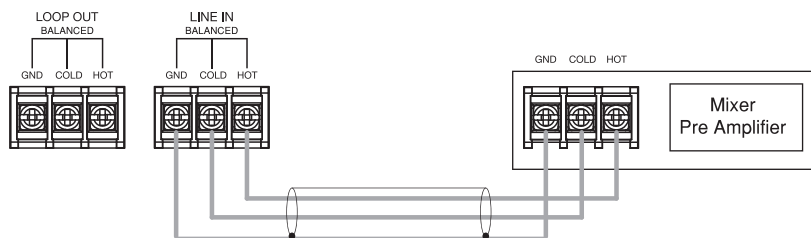

- **Connection with the mixer pre amplifier having the unbalanced type output**

Please make the length of the cable less than several meters.

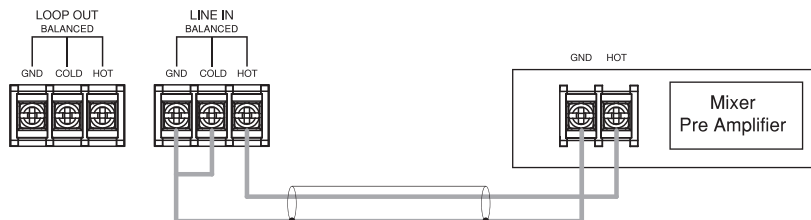

5.2. Speaker Connections

• Low Impedance Speaker

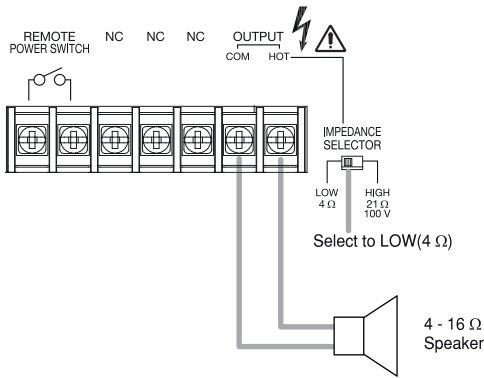

Note.
NC : not connected

• High Impedance Speaker

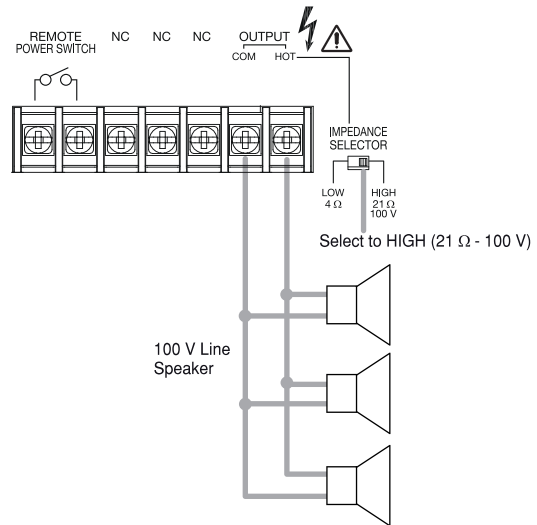

CAUTION!

- Turn off Amplifier when setting impedance output (LOW or HIGH).
- Impedance indicated at the terminal represent the total speaker system (load) impedances.
Total impedance of 100 V line : 21 Ω

⚠ CAUTION

Be sure to attach the supplied terminal cover after connection completion. Because high voltage is applied to the speaker terminals, never touch these terminals to avoid electric shock.

5.3. Example of External Equipment Connections

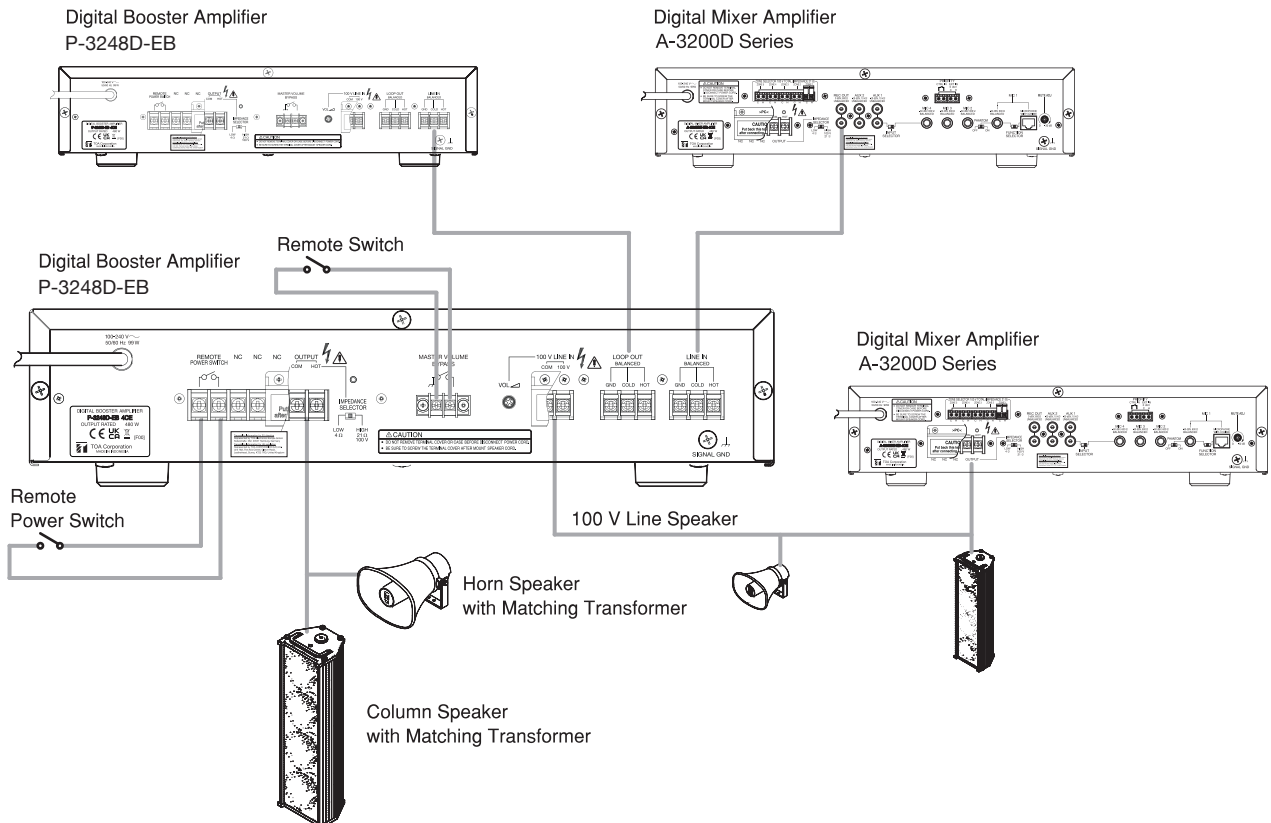

6. INSTALLATION

Keep the unit's all sides over 10 cm (3.94 inches) away from object that may obstruct air flow to prevent the unit's internal temperature rise.

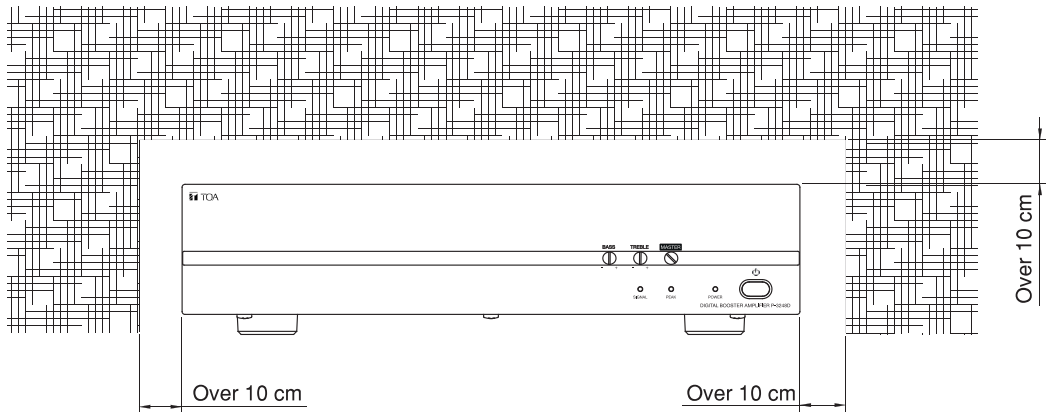

7. BLOCK AND LEVEL DIAGRAM

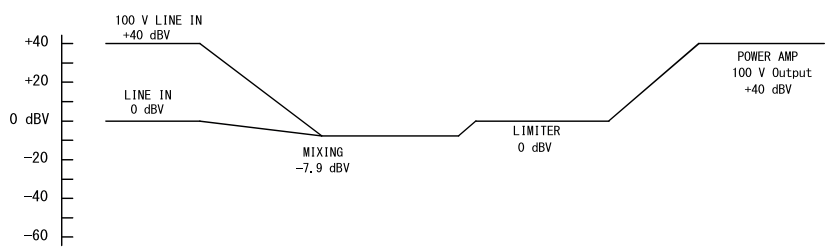
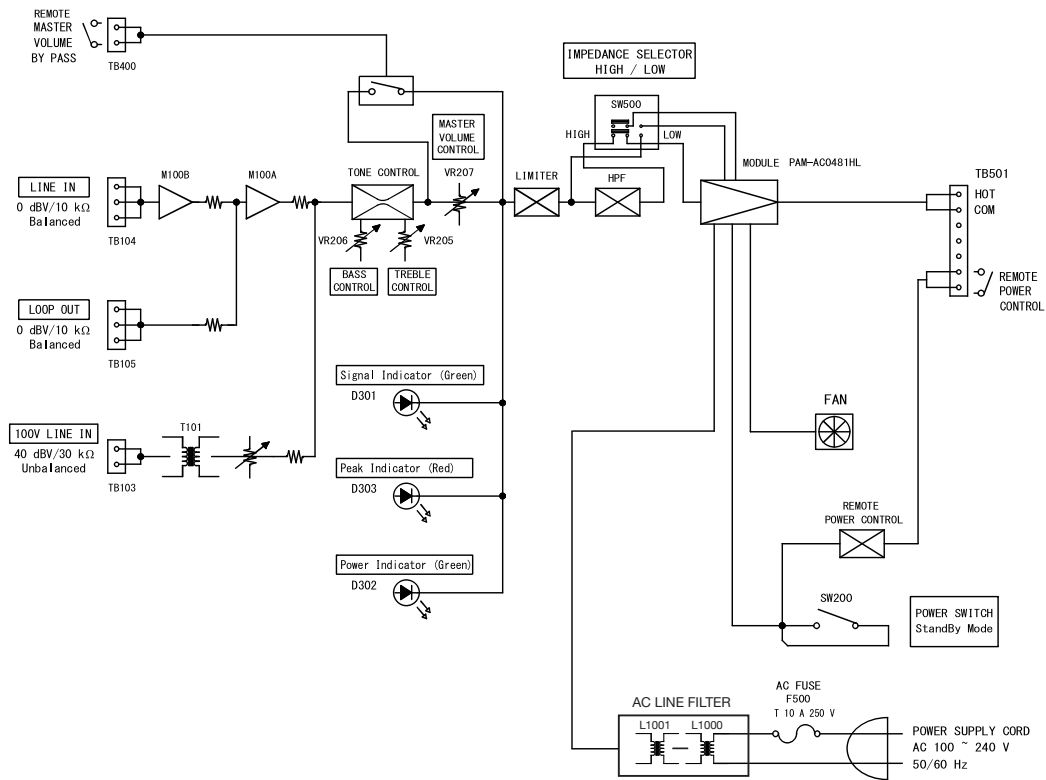

8. DIMENSIONAL DIAGRAM

units: mm (inches)

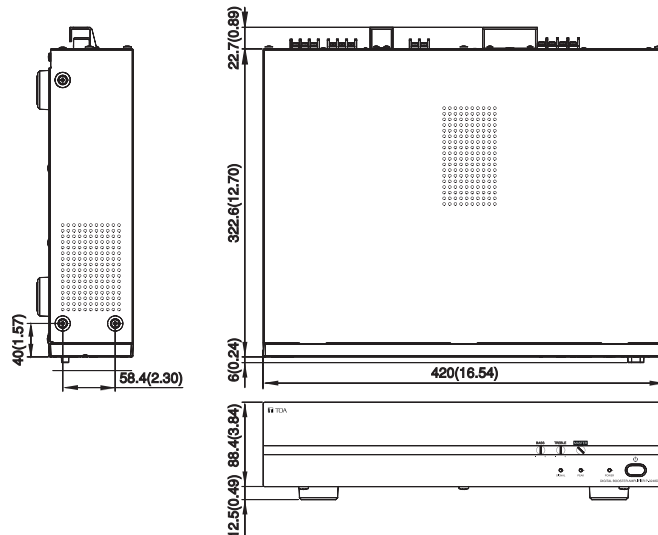

9. SPECIFICATIONS

Model No.	P-3248D-EB 1CE, P-3248D-EB 4CE	
Power Source	100 - 240 V AC 50/60 Hz	
Power Consumption (EN 62368-1)	99 W (AC operation at 1/8 maximum output without clip)	
Output Rated	480 W	
Input	Line In	0 dB*, 10 k Ω , balanced, screw terminal
	100 V Line In	40 dB*, 30 k Ω , unbalanced, screw terminal
Output	Speaker Out	Speaker output in screw type terminal
	Direct Line (selectable)	21 Ω (100 V)
		4 Ω
Loop Out	0 dB*, 10 k Ω , balanced, screw terminal	
Control	Remote power control, screw terminal Remote master volume bypass, screw terminal	
S/N Ratio	Over 70 dB	
Total Harmonic Distortion	Under 1% at 1 kHz, 1/3 rated power	
Frequency Response	50 - 20000 Hz	
Tone Control	Bass: \pm 10 dB at 100 Hz	
	Treble: \pm 10 dB at 10 kHz	
Indicator	POWER, SIGNAL, PEAK	
Operating Temperature	0 °C to +40 °C	
Ventilation	Fan Cooling	
Finish	Panel: ABS Resin, Black	
	Case: Steel Plate, Black	
Dimensions	420 (W) x 100.9 (H) x 351.3 (D) mm (16.54" x 3.97" x 13.83")	
Weight	5.2 kg (11.46 lb)	

* 0 dB = 1 V

Note : Design and specification are subject to change without prior notice for improvement.

Traceability information for Europe and UK

Manufacturer :
TOA Corporation
7-2-1, Minatojima-Nakamachi, Chuo-ku, Kobe, Hyogo,
Japan

Authorized representative Europe :
TOA Electronics Europe GmbH
Süderstraße 282, 20537 Hamburg, Germany

Authorized representative UK :
TOA CORPORATION (UK) Ltd.
Unit 7&8, The Axis Centre, Cleeve Road,
Leatherhead, Surrey, KT22 7RD, United Kingdom